

APPENDIX C: TYPICAL SECTIONS

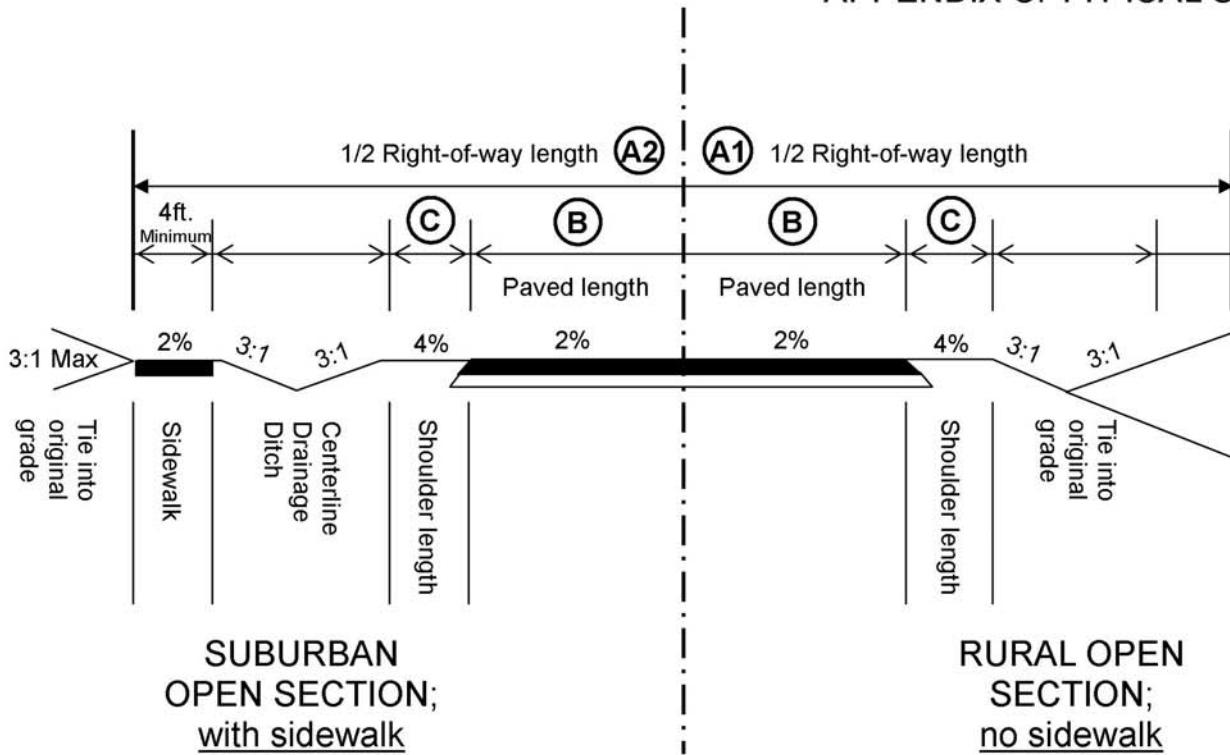

Street Type	Average Daily Traffic (ADT)	RURAL 1/2 Right-Of-Way Width (A1)	SUBURBAN 1/2 Right-Of-Way Width (A2)	Min. Pavement Width (B)	Min. Shoulder (C)	Max. Street Grade	Min. Street Grade	Design Speed (mph)
RURAL & SUBURBAN OPEN SECTION; with sidewalk								
Local I	ADT < 400	25ft.	30ft.	10ft.	4ft.*	12%	.5%	30
Local II	400 < ADT < 3000	25ft.	30ft.	11ft.	4ft.*	11%	.5%	40
Local III	ADT > 3000	25ft.	30ft.	12ft.	4ft.*	10%	.5%	45
Collector I	ADT < 1000	30ft.	30ft.	12ft.	4ft.*	10%	.5%	40
Collector II	1000 < ADT < 3000	30ft.	35ft.	12ft.	8ft.*	9%	.5%	45
Collector III	ADT > 3000	30ft.	35ft.	12ft.	10ft.*	8%	.5%	45
Arterial I	ADT < 5000	40ft.	40ft.	12ft.	10ft.*	6%	.5%	45
Arterial II	ADT > 5000	40ft.	40ft.	12ft.	12ft.*	5.5%	.5%	45

FOOTNOTES:

***Minimum Shoulders, Open Sections:**

- All Local I and II Roadways shall have a 4-foot-wide grass shoulder.
- All Local III and Collector I Roadways shall have 2-foot-wide paved shoulders with an additional 2ft. grass strip.
- All Collector II Roadways shall have 6-foot-wide paved shoulders with an additional 2ft. grass strip.
- All Collector III and Arterial I Roadways shall have 8-foot-wide paved shoulders with an additional 2ft. grass strip.
- All Arterial II Roadways shall have 10-foot-wide paved shoulders with an additional 2ft. grass strip.

Collector & Arterial Roads have restricted access as set forth in Article 3, Section 305 of the Dearborn County Subdivision Control Ordinance. *See also Article 24 of the Dearborn County Zoning Ordinance.*

The typical standards established in this Section can be amended by the Plan Commission if determined necessary for safety, efficiency, maintenance, anticipated problems or future growth as advised by the Planning Department and County Engineer.

APPENDIX C: TYPICAL SECTIONS

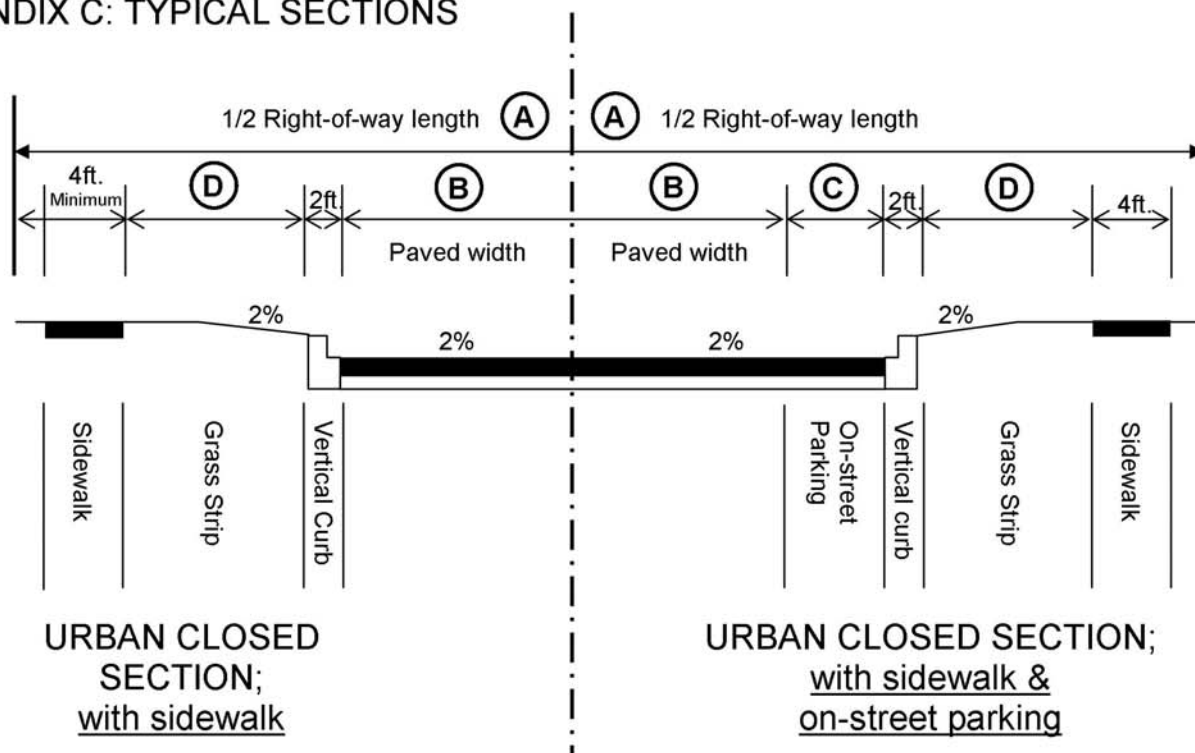

Street Type	Average Daily Traffic (ADT)	1/2 Right-Of-Way Width (A)	Min. Pavement Width (B)	On-Street Parking Width (C)	Min. Grass Strip (D)	Max. Street Grade	Min. Street Grade	Design Speed (mph)
URBAN CLOSED SECTION; with sidewalk								
Local I	ADT < 400	25ft.	10ft.	NA	5ft.	12%	.5%	30
Local II	400 < ADT < 3000	25ft.	11ft.	NA	5ft.	11%	.5%	40
Local III	ADT > 3000	25ft.	12ft.	NA	6ft.	10%	.5%	45
Collector I	ADT < 1000	30ft.	12ft.	NA	5ft.	10%	.5%	40
Collector II	1000 < ADT < 3000	30ft.	12ft.	NA	5ft.	9%	.5%	45
Collector III	ADT > 3000	30ft.	12ft.	NA	6ft.	8%	.5%	45
Arterial I	ADT < 5000	40ft.	12ft.	NA	6ft.	6%	.5%	45
Arterial II	ADT > 5000	40ft.	12ft.	NA	7ft.*	5.5%	.5%	45
URBAN CLOSED SECTION; with sidewalk AND on-street parking								
Local I	ADT < 400	25ft.	10ft.	4ft.	5ft.	12%	.5%	30
Local II	400 < ADT < 3000	28ft.	11ft.	5ft.	5ft.	11%	.5%	40
Local III	ADT > 3000	30ft.	12ft.	5ft.	6ft.	10%	.5%	45

FOOTNOTES:

*All projects involving U.S. 50, the distance between the vertical curb and sidewalk—or the minimum grass strip (D)—should be consistent with the U.S. 50 Corridor Transportation and Land Use Plan (2007).

Collector & Arterial Roads have restricted access as set forth in Article 3, Section 305 of the Dearborn County Subdivision Control Ordinance. See also Article 24 of the Dearborn County Zoning Ordinance.

The typical standards established in this Section can be amended by the Plan Commission if determined necessary for safety, efficiency, maintenance, anticipated problems or future growth as advised by the Planning Department and County Engineer.

APPENDIX C: TYPICAL SECTIONS

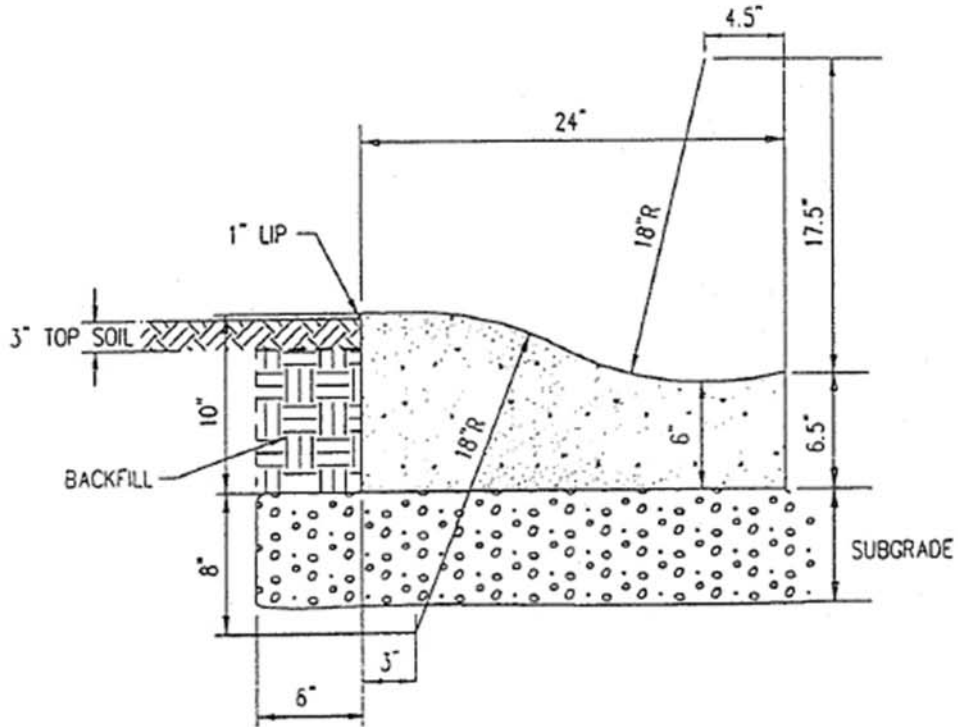

CONCRETE ROLL CURB & GUTTER

FOOTNOTES:

- Expansion joints are required at storm inlets.
- Contraction joints should be installed at 10' spacings.
- Spacing shall be 5' curve radii.
- Contraction joints shall be tooled or sawn in continuously poured curbs to a depth of 1/2 inch minimum.

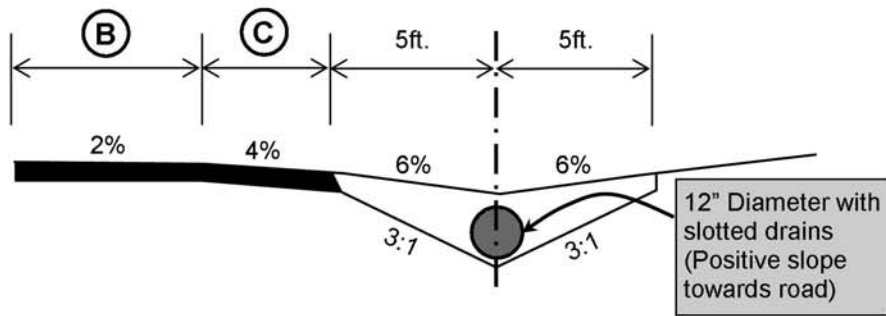

OPEN DRIVEWAY PROFILE

APPENDIX C: DETAILS

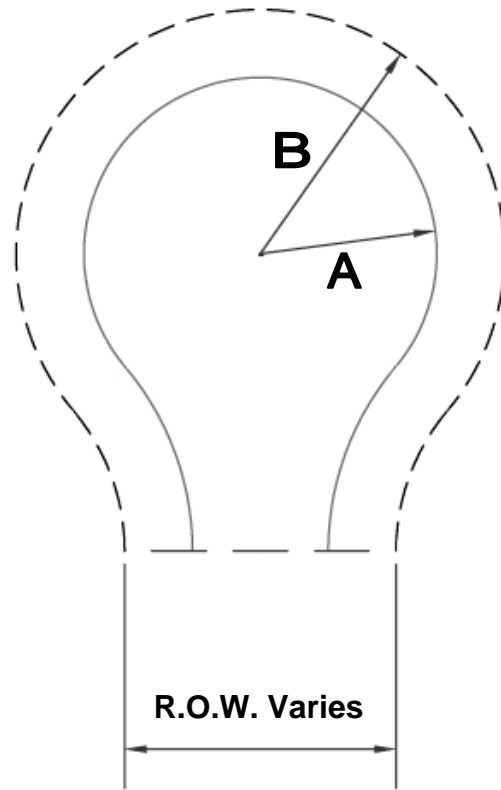

TYPICAL TURN AROUNDS FOR DEAD-END STREETS

A = 40-foot pavement radius, *Residential Streets*

B = 50-foot R.O.W. radius, *Residential Streets*

A = 50-foot pavement radius, *Commercial & Industrial Streets*

B = 60-foot R.O.W. radius, *Commercial & Industrial Streets*

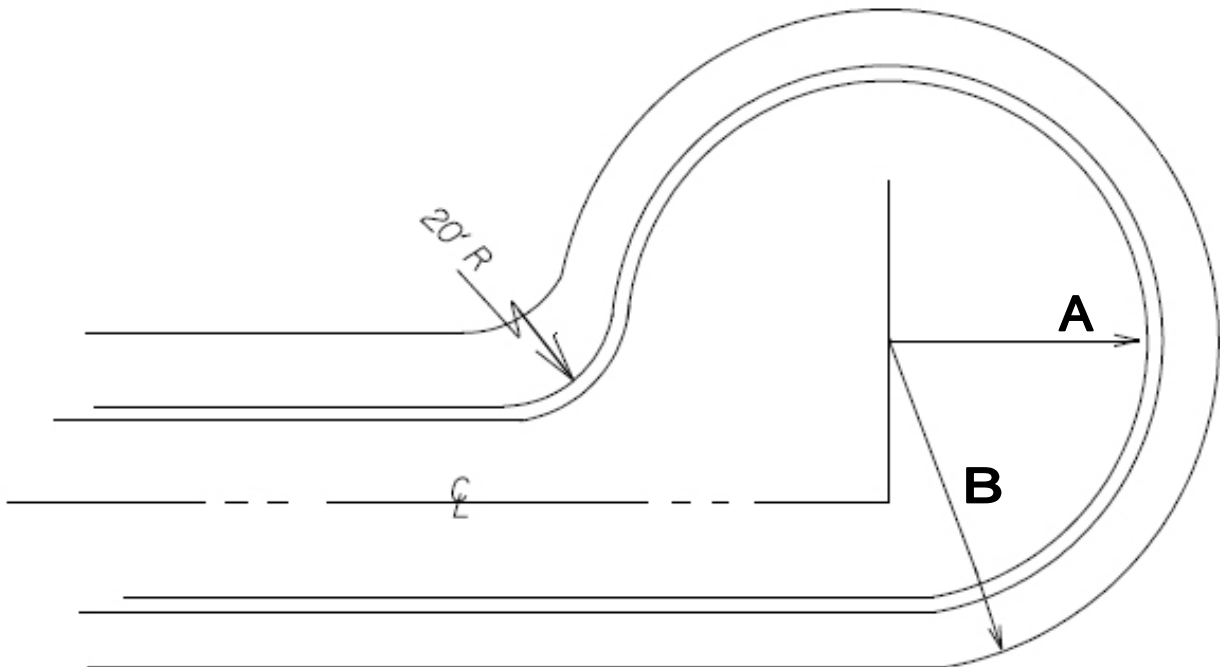

**OFFSET TURN AROUNDS FOR
DEAD-END STREETS**

A = 40-foot pavement radius, *Residential Streets*
B = 50-foot R.O.W. radius, *Residential Streets*

A = 50-foot pavement radius, *Commercial & Industrial Streets*
B = 60-foot R.O.W. radius, *Commercial & Industrial Streets*

APPENDIX C: DETAILS

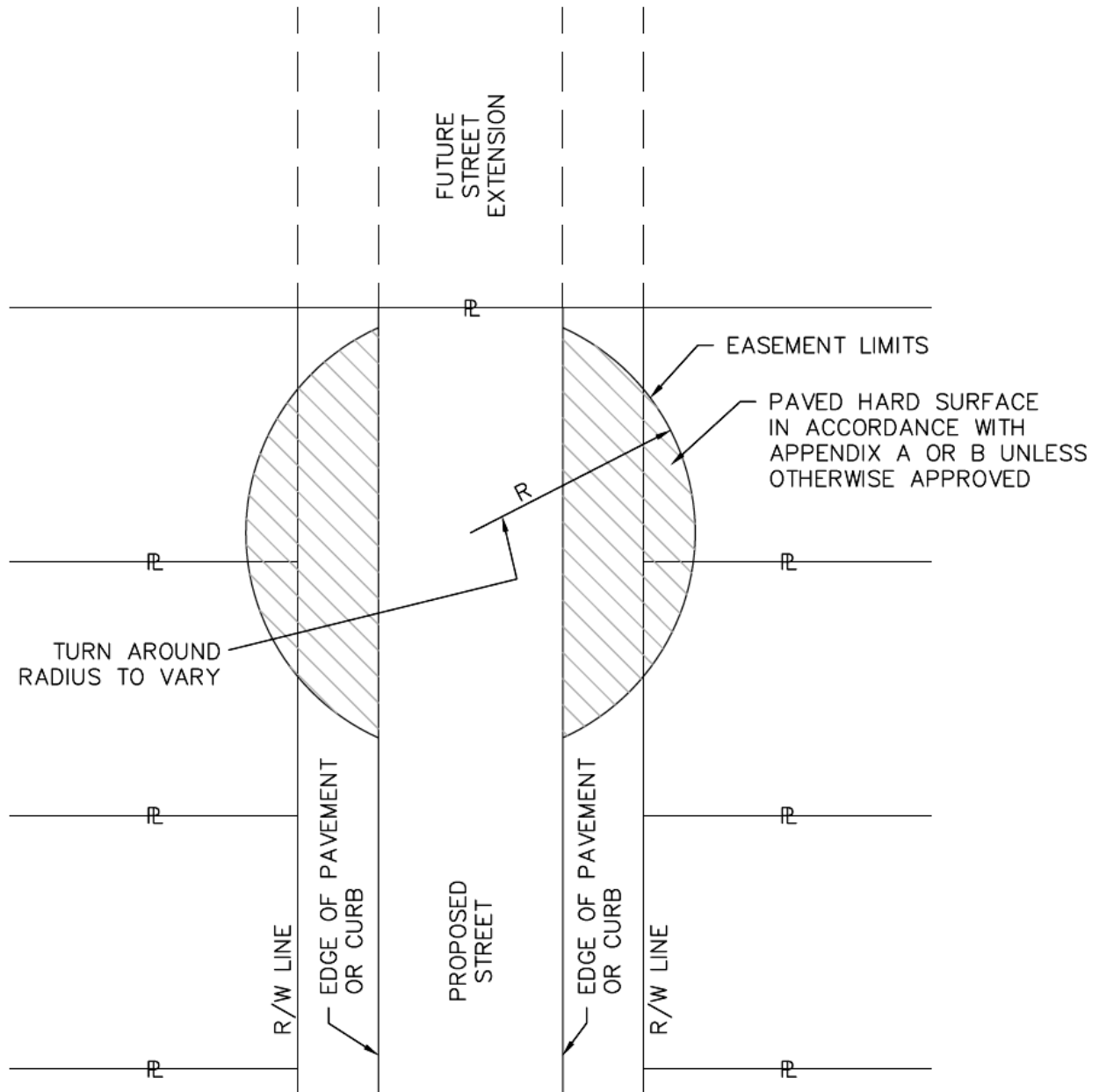

TEMPORARY TURNAROUND FOR FUTURE STREET EXTENSION

APPENDIX C: DETAILS

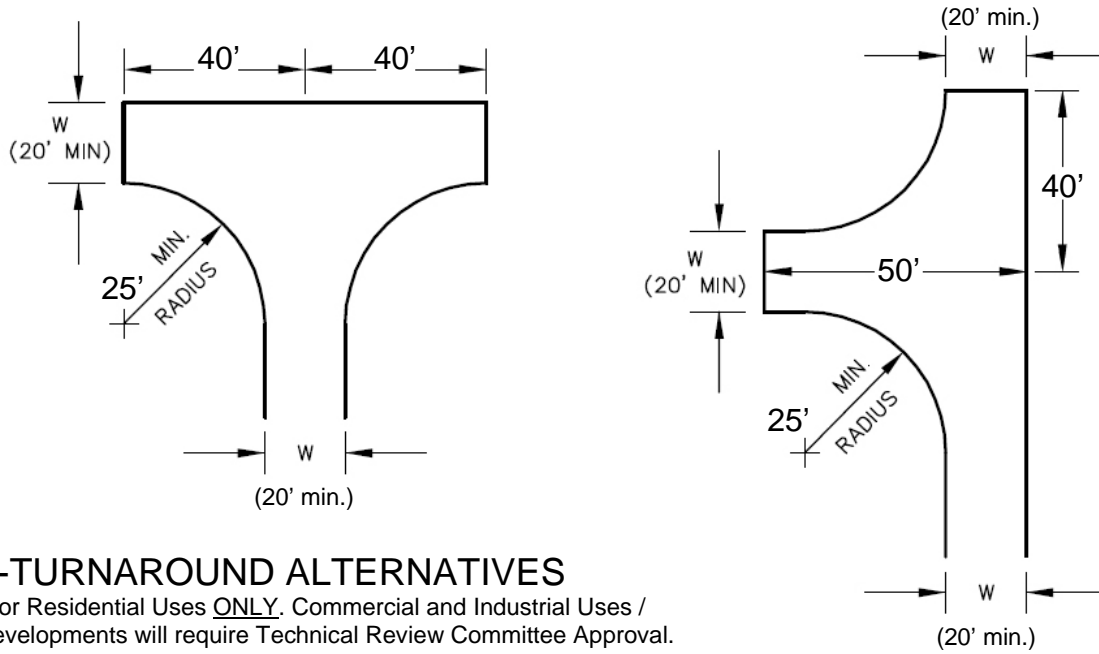

T-TURNAROUND ALTERNATIVES

*For Residential Uses ONLY. Commercial and Industrial Uses / Developments will require Technical Review Committee Approval.